

# HELICAL SHELL MILLS

*Heavy Duty Tooling for Large Diameter Applications*



**1.800.THREAD4**  
**advent-threadmill.com**



# HELICAL SHELL MILLS & INSERTS

MANY OTHER INSERT OPTIONS AVAILABLE SOON, CALL US FOR DETAILS.

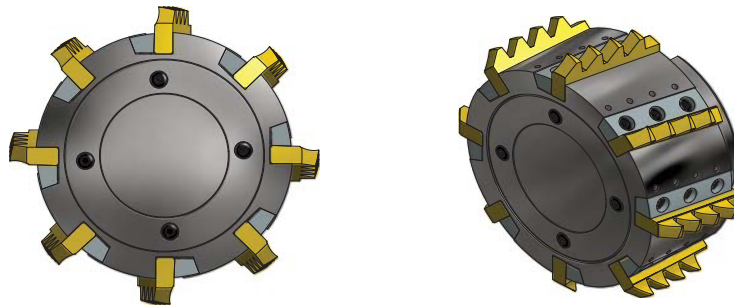

| Shellmills    |                     |        |        |        |                    |                  |            |                   |            |
|---------------|---------------------|--------|--------|--------|--------------------|------------------|------------|-------------------|------------|
| Part Number   | Cutter Diameter (D) |        |        |        | Face Diameter (d1) | Number of Flutes | Insert LOC | Hole Diameter (d) | Slot Width |
|               | Insert Height       |        |        |        |                    |                  |            |                   |            |
|               | 0.600"              | 0.650" | 0.700" | 0.950" |                    |                  |            |                   |            |
| SMH4015TA8-F8 | 4.000"              | 4.100" | 4.200" | 4.700" | 2.670"             | 8                | 1.500"     | 1.250"            | 0.500"     |
| SMH4020TA8-F8 | 4.000"              | 4.100" | 4.200" | 4.700" | 2.670"             | 8                | 2.000"     | 1.250"            | 0.500"     |

| Replacable Parts |                     |                 |                  |                       |                       |                    |
|------------------|---------------------|-----------------|------------------|-----------------------|-----------------------|--------------------|
| Part Number      | Seal Disc (4)       | Wedge (3)       | Locating Pin (2) | Pin Locking Screw (5) | Pin Pushing Screw (6) | Clamping Screw (7) |
| SMH4015TA8-F8    | ATM-SDSMH4015TA8-F8 | ATM-WSMH4015TA8 | ATM-PIN316516    | ATM-SESM4074          | ATM-SES83214          | PT483T-15IP        |
| SMH4020TA8-F8    | ATM-SDSMH4015TA8-F8 | ATM-WSMH4020TA8 | ATM-PIN316516    | ATM-SESM4074          | ATM-SES83214          | PT483T-15IP        |

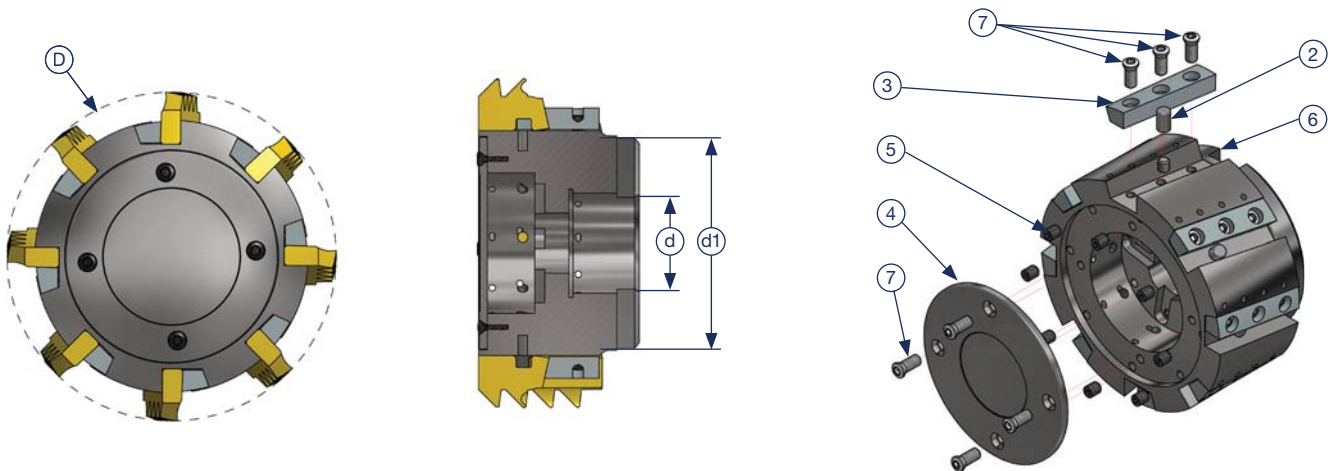

| Inserts            |                              |                 |               |        |                    |           |  |
|--------------------|------------------------------|-----------------|---------------|--------|--------------------|-----------|--|
| Part Number        | Pitch                        | For Use in Tool | Length of Cut | Height | Coatings Available |           |  |
|                    |                              |                 |               |        | Uncoated           | Z (TiAlN) |  |
| ITH4015-1BB7/45-15 | 1 TPI BRITISH BUTTRESS 7/45  | SMH4015TA8-F8   | 1.500"        | 0.950" | O                  | X         |  |
| ITH4015-3B7/45-15  | 3 TPI AMERICAN BUTTRESS 7/45 | SMH4015TA8-F8   | 1.500"        | 0.650" | O                  | X         |  |
| ITH4015-3BB7/45-15 | 3 TPI BRITISH BUTTRESS 7/45  | SMH4015TA8-F8   | 1.500"        | 0.600" | O                  | X         |  |
| ITH4015-4B7/45-15  | 4 TPI AMERICAN BUTTRESS 7/45 | SMH4015TA8-F8   | 1.500"        | 0.600" | O                  | X         |  |
| ITH4020-4B7/45-20  | 4 TPI AMERICAN BUTTRESS 7/45 | SMH4020TA8-F8   | 2.000"        | 0.600" | O                  | X         |  |